

Simulation is more than Software®

Verifiably strong



FKM inside ANSYS

CADFEM ANSYS Extension for Strength Assessment according to FKM Guideline with material database

Strongly integrated into ANSYS

The FKM guideline was developed by the Advisory Board for Engineering and Research for various applications in mechanical engineering and other sectors. FKM inside ANSYS allows the local strength assessment defined by this widespread computational algorithm to be supported within ANSYS Workbench, including in the form of parameter studies with change of material or surface treatment. As a complement, FKM inside ANSYS contains the WIAM material database for quick generation of material cards inside ANSYS Workbench.

Convincing tools

- WB/FKM – global, directive-compliant strength assessment of non-welded solid bodies according to FKM
- WB/FKM-Weld – Strength assessment of seam welds in shell and solid structures according to FKM
- WB/WIAM fatigue RIFEST – Strength assessment at test points for welded and non-welded components according to FKM
- WB/WIAM Engineering Data – material database for metallic materials

CAE-Support / Sale

Germany

P +49 (0) 80 92-70 05-46
vertrieb@cadfem.de

Austria

P +43 (0) 1-587 70 73
info@cadfem.at

Switzerland

P +41 (0) 52-368 01-01
info@cadfem.ch

FKM inside ANSYS

CADFEM ANSYS Extension for Strength Assessment according to FKM Guideline with material database

WB/FKM

Global, directive-compliant strength assessment, integrated into ANSYS Workbench, of non-welded solid bodies according to FKM

A frequent challenge in FEM is the evaluation of stress results, in particular with cyclic stresses. The FKM guideline "Analytical Strength Assessment of Components" describes a static strength assessment as well as a fatigue strength assessment. WB/FKM facilitates the evaluation of an FEM analysis by carrying out a global strength assessment according to the FKM guideline for the analytical models.

This has the following advantages over a manual assessment, for example:

- The complete integration in ANSYS Workbench enables fast and simple definition of the assessment parameters.
- The global test permits a fast and safe location of critically stressed points.
- The visualization of the degree of utilization facilitates advanced interpretation of the results.
- New in v18:
 - Automated stress assessment includes also transient analyses
 - Acceleration of workflow by parallelization of solver

WB/FKM-Weld

Directive-compliant strength assessment, integrated into ANSYS Workbench, of weld seams on shell and solid structures according to FKM

Analogous to the WB/FKM module, WB/FKM-Weld also facilitates the evaluation of stress results for cyclic stresses based on the FKM guideline "Analytical Strength Assessment of Components" through a static assessment and a fatigue assessment.

WB/FKM-Weld covers the strength assessment of welded shell and solid structures and also offers the following advantages:

- The complete integration in ANSYS Workbench enables fast and simple definition of the assessment parameters.
- User support during a search for and definition of weld seams.
- Presentation of results facilitated with visualization of the degree of utilization.
- Strength assessment of seam welds on solid structures in ANSYS Workbench with WB/FKM-Weld
- New in v18:
 - Automated stress assessment includes also transient analyses

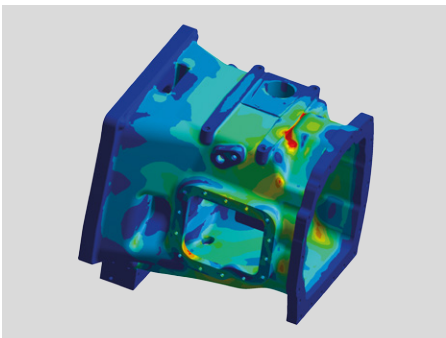

Integrated through WB/FKM into ANSYS Workbench: the strength assessment is compliant to FKM guideline

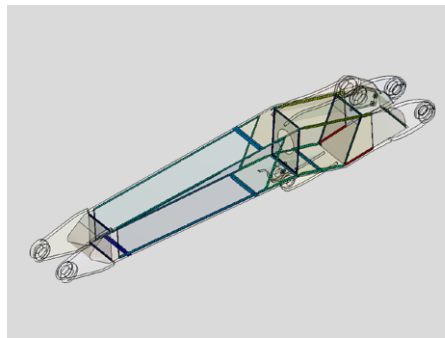

Strength assessment of seam welds on shell structures in ANSYS Workbench with WB/FKM-Weld

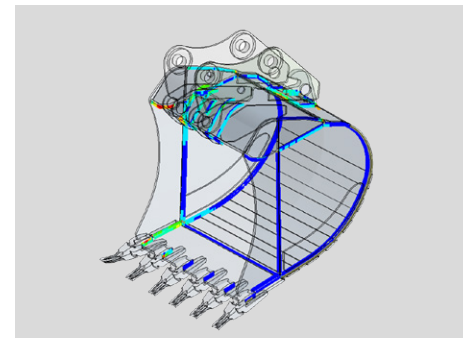

Strength assessment of seam welds on solid structures in ANSYS Workbench with WB/FKM-Weld

FKM inside ANSYS

CADFEM ANSYS Extension for Strength Assessment according to FKM Guideline with material database

WB/WIAM fatigue RIFEST

Fatigue Analysis integrated into ANSYS Workbench at assessment points for welded and non-welded components according to FKM

Integrated into ANSYS Workbench, the WB/WIAM fatigue RIFEST module supports the use of various Fatigue Assessments during component stress analyses. Among them are strength and fatigue limit tests according to the FKM guideline and the simulation of assessment points for welded and non-welded components. The module offers the degree of utilization quick, uncomplicated, parameter studies – such as variation of material selection, seam welding notch selection, or surface treatment – accelerating the verification process.

The most important functions of the module are:

- Fatigue Assessment with constant amplitude or with variable amplitude, including the required static Fatigue Analysis
- Fatigue Analysis for individual assessment points on the basis of existing local elastic stresses (such as those available from FEM simulations or strain gauge measurements)
- extensive database of welded and non-welded machinery components: Rolled steel, iron casting material, aluminum material (including material properties)
- normal and high temperatures



WB/WIAM fatigue RIFEST: The user receives a comprehensive report concerning all relevant parameters.

WB/WIAM Engineering Data

WIAM metallic material database integrated into ANSYS Workbench

The convenient WB/WIAM Engineering Data material database is based on the WIAM METALLINFO data pool and thus contains an extensive, up-to-date range of materials in one location. The material data includes norm history and international recoding.

The database is notable for the following:

- direct data import into ANSYS Workbench
- German and European standardization
- TÜV material performance sheets
- Steel and iron list and material data sheets, including those from manufacturers
- FKM guideline
- Ring trials and trial series at recognized universities
- Technical literature
- with sources comprehensively and precisely cited

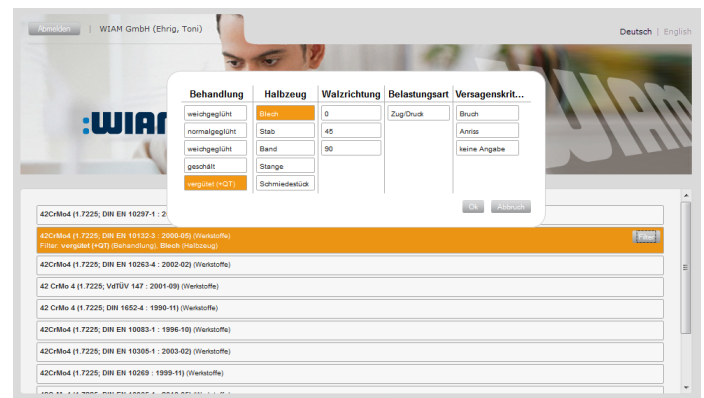

WB/WIAM Engineering Data material database: simple access to the latest material data

FKM inside ANSYS

CADFEM ANSYS Extension for Strength Assessment according to FKM Guideline with material database

Technical information

System requirements: ANSYS Workbench, Version 16 or later

www.cadfem.de/extensions



CADFEM is recognized for its CAE competence since 1985 and offers everything that determines the success of a simulation from one source: Software and IT solutions. Advice, support, engineering. Know-how transfer. As the ANSYS Competence Center FEM, we support ANSYS users in Central Europe.

www.cadfem.net



ANSYS is the world's biggest provider of simulation software and offers programs for almost every application. ANSYS is one of the most widely used CAE solutions in industry, research, and teaching.

www.ansys.com

FKM inside ANSYS is a product of CADFEM GmbH, the firm of The Engineering Office of Huß & Feickert (ihf), and IMA Material Research & Application Engineering (Materialforschung und Anwendungstechnik GmbH); WIAM is a product of IMA Materialforschung und Anwendungstechnik GmbH; ANSYS Workbench is a product of ANSYS, Inc.; Images: CADFEM GmbH; IMA Materialforschung und Anwendungstechnik GmbH

Last revised March 2017: Subject to changes and corrections



The Engineering Office of Huß & Feickert (ihf) is an engineering service provider in the area of computational simulation and the development of software for use with the finite-element method, working with prestigious customers in the automobile industry and their suppliers and the manufacturing plants for construction machinery, aerospace, as well as consumer goods and chemicals industries.

www.ihf-ffm.de



IMA Materialforschung und Anwendungstechnik GmbH in Dresden (IMA Dresden) develops and implements customized tests for any material or component. In IMA you will find comprehensive engineering competence in the areas of strength, fatigue, and stress analyses.

www.ima-dresden.de

CADFEM GmbH
Marktplatz 2
85567 Grafing near Munich
P +49 (0)8092-7005-0
info@cadfem.de
www.cadfem.de

Further Offices:
Berlin, Chemnitz,
Dortmund, Frankfurt,
Hannover und Stuttgart

CADFEM (Austria) GmbH
Wagenseilgasse 14
1120 Wien
P +43 (0)1-587 70 73
info@cadfem.at
www.cadfem.at

CADFEM (Suisse) AG
Wittenwilerstrasse 25
8355 Aadorf
P +41 (0)52-368 01-01
info@cadfem.ch
www.cadfem.ch